



## 16 Denison Street Mudgee NSW

3  1  2 

Not only is this home in a highly sought after East Mudgee location, it has also been tastefully renovated throughout, meaning it is instantly ready for you to move yourself or a tenant in and enjoy!

- Three well sized bedrooms, all with built-in wardrobes and ceiling fans
- Galley style kitchen with great cupboard space including a double pantry and new appliances
- Spacious separate living and dining areas are both air-conditioned and a cosy wood fire to sit by
- Well renovated bathroom plus the always convenient 2nd toilet
- There is also 9x4m shed with awning

This home has all the features for a buyer who wants to move in a do nothing or an investor looking for a quality long term tenant or a perfect short stay property.

**Price** : \$ 380,000  
**Land Size** : 716 sqm  
**View** : <https://www.thepropertyshop.com.au/sale/nsw/dubbo-orana/mudgee/residential/house/5659499>



**Sara Perry**  
**02 6372 2222**

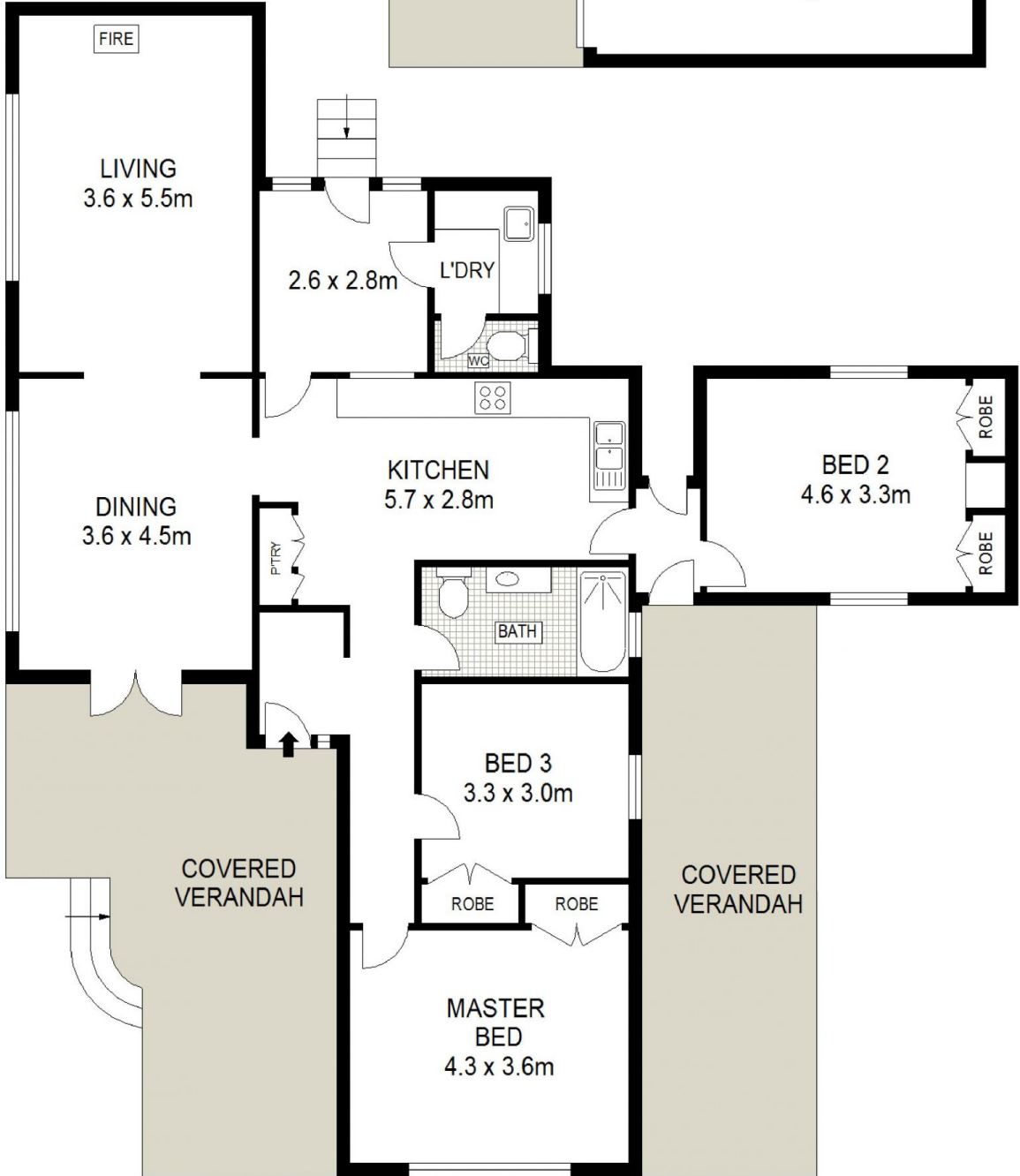
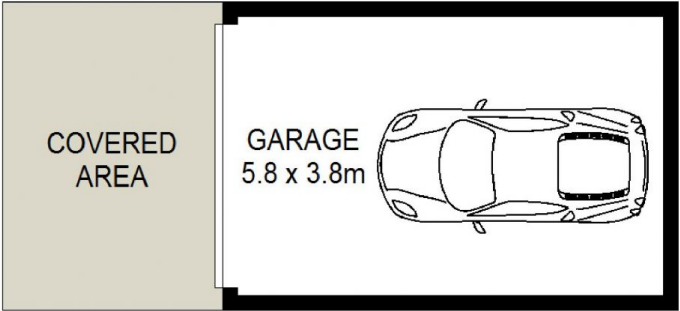

GROUND LEVEL

16 DENISON STREET

MUDGEES

